

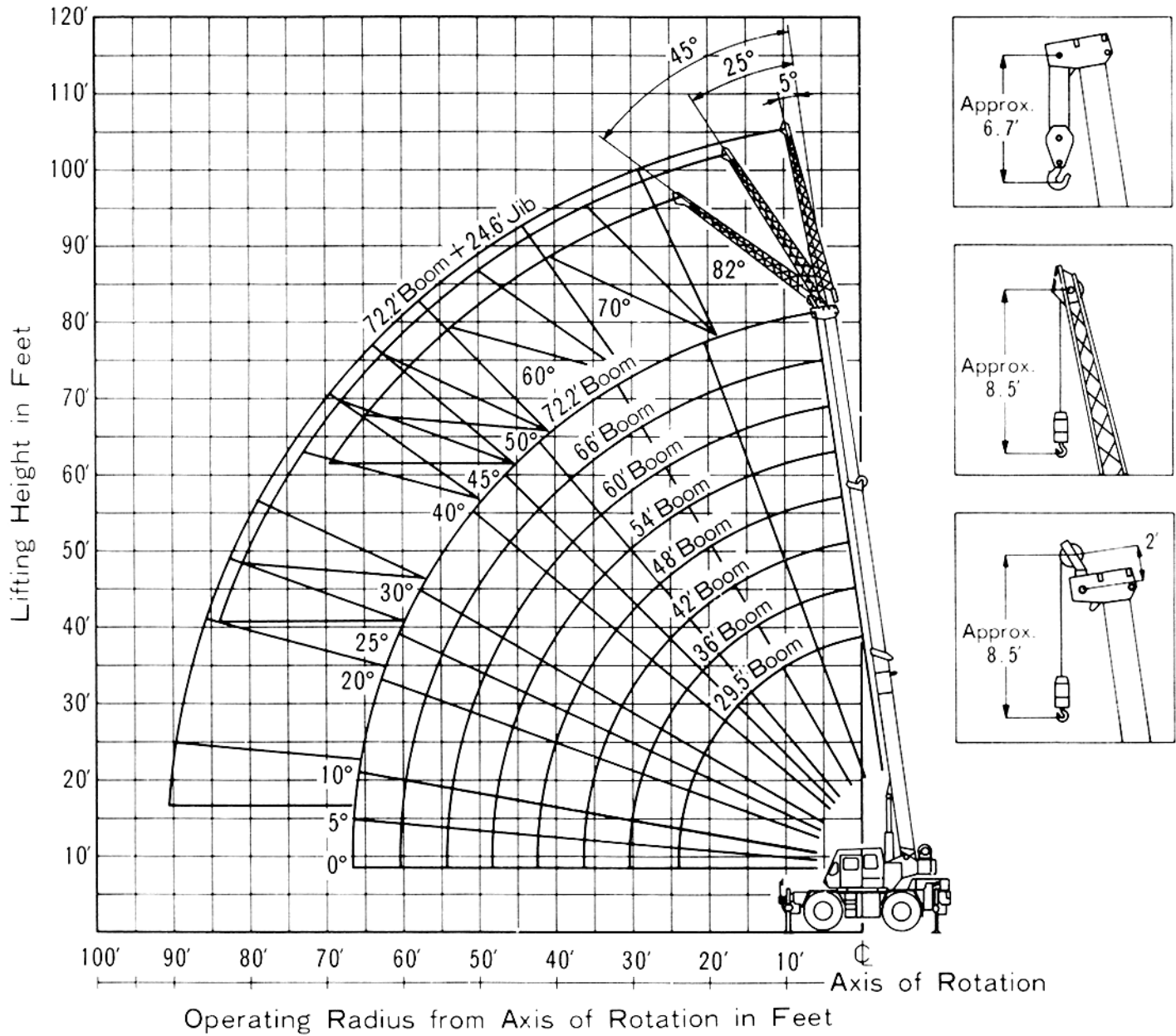

OPERATING RADIUS/LIFTING HEIGHT CHART



NOTE: Boom and jib geometry shown are for unloaded condition and machine standing level on firm supporting surface. Boom deflection and subsequent radius and boom angle change must be accounted for when applying load to hook.

TR-280XL TOTAL RATED LOAD CHART (IN POUNDS)

| ON OUTRIGGERS FULLY EXTENDED 360° ROTATION | | | | | | | | |
|--|---------------------|--------------|--------------|--------------|--------------|--------------|--------------|--------------|
| Load Radius In Feet | Boom Length in Feet | | | | | | | |
| | 29.5 (9.0m) | 36 (11.0m) | 42 (12.8m) | 48 (14.6m) | 54 (16.5 m) | 60 (18.3m) | 66 (20.1m) | 72.2 (22.0m) |
| 10 | 56,000 (60°) | 36,000 (66°) | 36,000 (70°) | 35,000 (73°) | 29,750 (75°) | 29,150 (76°) | 22,250 (77°) | 20,850 (80°) |
| 12 | 40,000 (56°) | 36,000 (62°) | 36,000 (67°) | 35,000 (70°) | 29,750 (72°) | 29,150 (74°) | 22,250 (76°) | 20,850 (77°) |
| 15 | 31,700 (48°) | 31,500 (57°) | 31,500 (62°) | 31,200 (66°) | 29,750 (69°) | 29,150 (71°) | 22,250 (73°) | 20,850 (74°) |
| 20 | 24,000 (32°) | 24,000 (47°) | 24,000 (54°) | 24,000 (59°) | 24,000 (63°) | 23,100 (66°) | 22,250 (68°) | 20,850 (70°) |
| 25 | | 18,800 (34°) | 18,800 (45°) | 18,800 (52°) | 18,800 (57°) | 18,800 (61°) | 18,300 (64°) | 17,650 (66°) |
| 30 | | 15,900 (9°) | 15,900 (34°) | 15,900 (44°) | 15,900 (50°) | 15,900 (55°) | 15,300 (58°) | 14,950 (61°) |
| 35 | | | 12,900 (16°) | 12,900 (34°) | 12,900 (43°) | 12,900 (49°) | 12,900 (53°) | 12,700 (57°) |
| 40 | | | | 10,800 (19°) | 10,800 (34°) | 10,800 (42°) | 10,800 (47°) | 10,800 (52°) |
| 45 | | | | | 9,020 (21°) | 9,020 (34°) | 9,020 (41°) | 9,020 (46°) |
| 50 | | | | | | 7,420 (23°) | 7,420 (34°) | 7,420 (41°) |
| 55 | | | | | | | 6,200 (24°) | 6,200 (34°) |
| 60 | | | | | | | 5,200 (6°) | 5,200 (25°) |
| 65 | | | | | | | | 4,400 (12°) |

TR-280XL TOTAL RATED LOAD CHART (JIB CAPACITIES)

| ON OUTRIGGERS FULLY EXTENDED 360 ROTATION | | | | | | |
|---|-------------------------------------|------------------------|-----------------|------------------------|-----------------|------------------------|
| Boom Angle In Degree | Boom Length in Feet | | | | | |
| | 72.2' (22m) Boom + 24.6' (7.5m) Jib | | | | | |
| | 5° Tilt | | 25° Tilt | | 45° Tilt | |
| | Load Radius Ft. | Total Rated Load (lbs) | Load Radius Ft. | Total Rated Load (lbs) | Load Radius Ft. | Total Rated Load (lbs) |
| 80 | 15.2' | 8,800 | 22.4' | 4,410 | 28.1' | 3,300 |
| 75 | 24.0' | 8,260 | 30.6' | 4,410 | 35.7' | 3,300 |
| 70 | 32.1' | 6,920 | 38.5' | 4,410 | 42.8' | 3,100 |
| 65 | 39.9' | 5,920 | 45.8' | 4,000 | 49.6' | 2,960 |
| 60 | 47.3' | 5,190 | 52.7' | 3,750 | 55.9' | 2,860 |
| 55 | 54.3' | 4,590 | 59.2' | 3,560 | 61.7' | 2,760 |
| 50 | 60.7' | 4,090 | 65.2' | 3,400 | 66.9' | 2,660 |
| 45 | 66.7' | 3,710 | 70.6' | 3,290 | 71.6' | 2,550 |
| 40 | 72.1' | 3,420 | 75.3' | 3,180 | | |
| 35 | 76.8' | 3,190 | 79.4' | 3,100 | | |
| 30 | 80.9' | 2,820 | 82.9' | 2,800 | | |
| 25 | 84.4' | 2,530 | 85.6' | 2,500 | | |
| 20 | 87.1' | 2,300 | | | | |
| 15 | 89.2' | 2,100 | | | | |
| 10 | 90.6' | 1,900 | | | | |
| 5 | 91.3' | 1,800 | | | | |

1,650 lbs. (750 kg) shall be subtracted from the total rated load of the main boom when jib is attached to the main boom head.

HOISTING SPECIFICATIONS

LINE SPEEDS AND PULLS

| Layer | Speed | Main or auxiliary hoist – 12 5/8" (0.32) drum | | | | | |
|---------|-------|---|-------|---------------|------|-----------------|------|
| | | Line Speeds (2) | | Line pulls | | | |
| | | F.P.M | M/min | Available (1) | | Permissible (4) | |
| | | | | Lbs. | kgf | Lbs. | kgf |
| 1st | Low | 118 | 36 | 11,086 | 5028 | 10,078 | 4571 |
| | High | 236 | 72 | | | | |
| 2nd | Low | 130 | 40 | 10,642 | 4827 | 9675 | 4388 |
| | High | 259 | 79 | | | | |
| 3rd | Low | 141 | 43 | 10,270 | 4658 | 9336 | 4235 |
| | High | 282 | 86 | | | | |
| 4th | Low | 153 | 47 | 9953 | 4515 | 9048 | 4104 |
| | High | 305 | 93 | | | | |
| 5th | Low | 164 | 50 | 9680 | 4391 | 8800 | 3992 |
| | High | 328 | 100 | | | | |
| 6th (3) | Low | 176 | 54 | 9442 | 4283 | 8584 | 3893 |
| | High | 351 | 107 | | | | |

- (1) Developed by machinery with first layer of wire rope, but not based on rope strength or other limitation in machinery or equipment.
- (2) Line speeds based only on hook block, not loaded.
- (3) Sixth layer of wire rope is not recommended for hoisting operations.
- (4) Permissible line pull may be affected by wire rope strength.

DRUM WIRE ROPE CAPACITIES

| Wire Rope Layer | Main Drum Grooved Lagging 5/8" (16 mm) wire rope | | | | Aux. Drum Grooved Lagging 5/8" (16 mm) wire rope | | | |
|-----------------|--|--------|-----------------|--------|--|--------|-----------------|--------|
| | Rope per layer | | Total wire rope | | Rope per layer | | Total wire rope | |
| | Feet | Meters | Feet | Meters | Feet | Meters | Feet | Meters |
| 1 | 99 | 30.1 | 99 | 30.1 | 54 | 16.4 | 54 | 16.4 |
| 2 | 108 | 32.9 | 207 | 63.0 | 59 | 17.9 | 113 | 34.3 |
| 3 | 117 | 35.8 | 324 | 98.8 | 64 | 19.5 | 117 | 53.8 |
| 4 | 127 | 38.7 | 451 | 137.5 | 69 | 21.0 | 245 | 74.8 |
| 5 | 136 | 41.6 | 588 | 179.1 | 74 | 22.6 | 320 | 97.4 |
| 6 | 146 | 44.5 | 734 | 223.6 | 79 | 24.2 | 399 | 121.6 |

DRUM DIMENSIONS

| | MAIN | | AUXILIARY | |
|-----------------|---------|-------|-----------|-------|
| | Inch | mm | Inch | mm |
| Root Diameter | 12 5/8 | 320 | 12 5/8 | 320 |
| Length | 19 1/16 | 484.5 | 10 3/8 | 263.5 |
| Flange Diameter | 20 7/8 | 530 | 20 7/8 | 530 |

LIFTING CAPACITIES (ON RUBBER)

TIRE: 20.5 – 25 – 20PR

| Load Radius In Feet | ON RUBBER | | |
|---------------------|------------|---------------|------------|
| | Stationary | | Creep |
| | Over Front | 360° Rotation | Over Front |
| 10 | 32,000 (a) | 23,700 (f) | 24,650 (a) |
| 12 | 27,800 (a) | 17,800 (g) | 21,200 (a) |
| 15 | 20,300 (c) | 12,400 (h) | 17,380 (c) |
| 20 | 13,470 (d) | 7,720 (h) | 13,470 (d) |
| 25 | 9,650 (h) | 5,220 (h) | 9,650 (h) |
| 30 | 7,250 (h) | 3,650 (h) | 7,250 (h) |
| 35 | 5,570 (h) | 2,600 (h) | 5,570 (h) |
| 40 | 4,350 (h) | 1,840 (h) | 4,350 (h) |
| 45 | 3,430 (h) | 1,250 (h) | 3,430 (h) |
| 50 | 2,730 (h) | | 2,730 (h) |

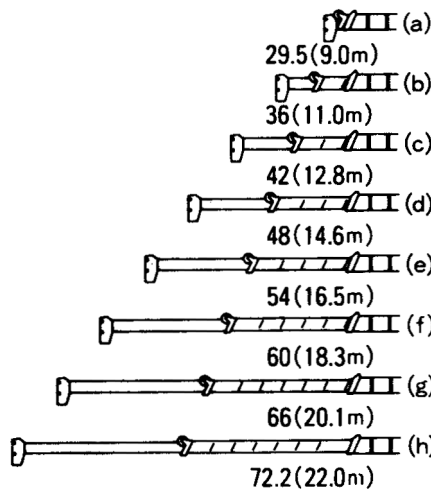

Boom Length in Feet

Working Area

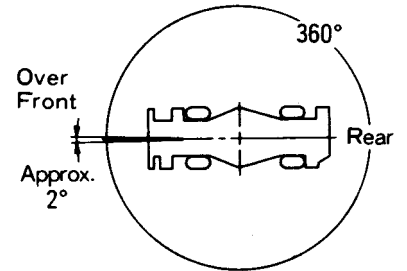

Max. Permissible Boom Length in Feet for On Rubber Lifting Capacities.

- | | |
|------------------|-------------------|
| (a) 29.5 (9.0 m) | (e) 54 (16.5 m) |
| (b) 36 (11.0 m) | (f) 60 (18.3 m) |
| (c) 42 (12.8 m) | (g) 66 (20.1 m) |
| (d) 48 (14.6 m) | (h) 72.2 (22.0 m) |

NOTE: Boom angles are in degrees

| Boom Length in Feet (meters) | 29.5' (9.0) | 36' to 60' (11.0 to 18.3) | 66' to 72.2' (20.1 to 22.0) | On Rubber 29.5' to 72.2' (9.0 to 22.0) | Single top Jib |
|------------------------------|-------------|---------------------------|-----------------------------|--|----------------|
| No. of part line | 8 | 6 | 4 | 4 | 1 |

The lifting capacity data are stored in the Load Moment Indicator (AML-M) based on the standard number of parts of line listed in the above chart. Standard number of parts of line should be according to the above chart.

WARNING AND OPERATING INSTRUCTIONS FOR LIFTING CAPACITIES

GENERAL

1. Total rated loads shown on the TOTAL RATED LOAD CHART apply only to the machine as originally manufactured and normally equipped by TADANO LTD. Modifications to the machine or use of optional equipment other than that specified can result in a reduction of capacity.
2. Construction equipment can be dangerous if improperly operated or maintained. Operation and maintenance of this machine must be in compliance with the information in the operation, safety and maintenance manual supplied with machine. If this manual is missing, order replacement through the distributor.
3. The operator and other personnel associated with this machine shall fully acquaint themselves with the latest applicable American National Standards Institute (ANSI) safety standards for cranes.

SET UP

1. Total rated loads shown on the chart are the maximum allowable crane capacities and are based on the machine standing level on firm supporting surface under ideal job conditions. Depending on the nature of the supporting surface, it may be necessary to have structural supports under the outrigger floats or tires to spread the load to a larger bearing surface.
2. For outrigger operation, outriggers shall be fully extended with tires free of supporting surface before operating crane.

OPERATION

1. Total rated loads with outriggers fully extended do not exceed 85% of the tipping loads as determined by SAE Crane Stability Test Code J-765.
2. Total rated loads above bold lines in the chart are based on crane strength and those below, on its stability. They are based on actual load radius increased by boom deflection.
3. Total rated loads include the weight of main hook block (600 lbs for 30 tons capacity), auxiliary hook ball (220 lbs for 4.4 tons capacity), sling and auxiliary lifting devices and their weights shall be subtracted from the listed capacities to obtain the net load to be lifted.
4. Total rated loads are based on freely suspended loads and make no allowance for such factors as the effect of wind, sudden stopping of loads, supporting surface conditions, inflation of tires, operating speeds, side loads, etc. Side pull on boom or jib is extremely dangerous.
5. Total rated loads do not account for wind on lifted load or boom. Total rated loads and boom length shall be appropriately reduced, when wind velocity is above 20 mph (9m/ sec.).
6. Total rated loads at load radius shall not be exceeded. Do not tip the crane to determine allowable loads.
7. Do not operate at boom lengths beyond radii or boom angle, where no capacities are shown. Crane may overturn without any load on the hook.
8. When boom length is between values listed, refer to the total rated loads of the next longer and next shorter booms for the same radius. The lesser of the two total rated loads shall be used.

9. When making lifts at a load radius not shown, use the next longer radius to determine allowable capacity.
10. Single line operation should not exceed 8,800 lbs (4000 kg).
11. Loaded boom angles are approximate. The boom angle before loading should be greater to account for deflection.
12. The 29.5' (9.0 m) boom length capacities are based on boom fully retracted. If not fully retracted [less than 36' (11.0 m) boom length], use the total rated loads for the 36' (11.0 m) boom length.
13. Extension or retraction of the boom with loads may be attempted within the limits of the TOTAL RATED LOAD CHART. The ability to telescope loads is limited by hydraulic pressure, boom angle, boom length, crane maintenance, etc.
14. For lifting capacity of single top, reduce the total rated loads of relevant boom by 550 lbs (250 kg). Capacities of single top shall not exceed 6,610 lbs (3000 kgs) including main hook.
15. When erecting and stowing jib, be sure to retain it by hand or by other means to prevent its free movement.
16. 1650 lbs (750 kgs) shall be subtracted from the total rated loads of the main boom, when jib is attached to main boom head. Jib weight is 770 lbs (350 kgs).
17. Use Anti-Two Block (OVERWIND CUTOFF) disable switch when erecting and stowing the jib and stowing the hook block. While the switch is pushed, the hoist does not stop, even when overwind condition occurs.
18. For boom lengths with 24.6' (7.5 m) Jib, total rated loads are determined by loaded boom angle only in the column headed "72.2' (22 m) Boom + 24.6' (7.5m) Jib". For boom angles not shown, use the next lower loaded boom angle to determine allowable capacity.
19. When lifting a load by using jib (auxiliary hoist) and boom (main hoist) simultaneously, do the following:
 - Illuminate the jib indicator lamps and make the jib offset display screen indicate the same value as the actual offset by repeatedly pushing the boom state register switch.
 - Before starting operation, make sure that the weight of load is within the total rated load for jib.

DEFINITIONS

1. *Load Radius*: Horizontal distance from a projection of the axis of rotation to supporting surface before loading to the center of the vertical hoist line or tackle with load applied.
2. *Loaded Boom Angle*: The angle between the boom base section and the horizontal, after lifting the total rated load at the load radius.
3. *Working Area*: Area measured in a circular arc about the centerline of rotation.
4. *Freely Suspended Load*: Load hanging free with no direct external force applied except by the hoist line.
5. *Side Load*: Horizontal side force applied to the lifted load either on the ground or in the air.

WARNING AND OPERATING INSTRUCTIONS FOR ON RUBBER CAPACITIES

1. Total rated loads on rubber are in pounds and do not exceed 75% of tipping loads as determined by test in accordance with SAE J-765.
2. Total rated loads shown in the chart are based on condition that crane is set on firm level surfaces with suspension lock applied. Those above bold lines are based on tire capacity and those below, on crane stability. They are based on actual load radius increased by tire deformation and boom deflection.
3. Total rated loads are based on proper tire inflation, capacity and condition. Damaged tires are hazardous to safe operation of crane.
4. Tires shall be inflated to correct air pressure.
5. Over front operation shall be performed within two degrees in front of chassis.
6. On rubber lifting with "jib" and "auxiliary lifting sheave" (single top) are not permitted.
7. When making lift on rubber, set parking brake.
8. For creep operation, boom must be centered over front of machine, swing lock engaged, and load restrained from swinging. Travel slowly and keep the lifted load as close to the ground as possible, and especially avoid any abrupt steering, accelerating or braking.
9. Do not operate the crane while carrying the load.
10. Creep is motion for crane not to travel more than 200 feet (60 m) in any 30 minute period and to travel at the speed of less than 1 mph (1.6 km/h).

TIRE AIR PRESSURE
20.50-25-20PR -80 psi (5.6 kgf/cm²)

WARNING AND OPERATING INSTRUCTIONS FOR USING THE LOAD MOMENT INDICATOR (AML-M)

Notes for Load Moment Indicator

1. When operating crane on outriggers:
 - Set P.T.O. switch to "ON".
 - Push the outrigger state register switch to illuminate the outrigger indicator lamps.
 - Push the boom state register switch repeatedly until the state of the indicator lamps and the offset display screen conforms to the actual state of the boom, the single top and the jib.
 - When erecting and stowing jib, push boom state register switch repeatedly until jib indicator lamps flicker (in jib erection/stowing mode).
 2. When operating crane on rubber:
 - Lock suspension springs with boom over front and crane in traveling configuration.
 - Set P.T.O. switch to "ON".
 - Push the boom state register switch repeatedly to illuminate the boom indicator lamp.
 - Push the on rubber state register switch to illuminate the on rubber indicator lamps. By repeatedly pushing the on rubber register switch, stationary and creep operation are selected alternately. When creep operation is selected, the on rubber indicator lamps flicker.
- However, pay attention to the following.
- (1) For stationary operation.
 - The front capacities are attainable only when the over front indicator lamp is on. When the boom is more than 2 degrees from centered over front of chassis, 360° capacities are in effect.
 - When a load is lifted in the front position and then swung to the side area, make sure the value of the LOAD MOMENT INDICATOR (AML-M) is below the 360° lifting capacity.
 - (2) For creep operation.
 - The creep capacities are attainable only when boom is in the straight forward position of chassis and the over front indicator is on. If boom is not in the straight forward position of chassis, never lift load.
 3. During crane operation, make sure that the displays on front panel are in accordance with actual operating conditions.
 4. The displayed values of LOAD MOMENT INDICATOR (AML-M) are based on freely suspended loads and make no allowance for such factors as the effect of wind, sudden stopping of loads, supporting surface conditions, inflation of tire, operating speed, side loads, etc. For safe operation, it is recommended when extending and lowering boom or swinging, lifting loads shall be appropriately reduced.
 5. LOAD MOMENT INDICATOR (AML-M) is intended as an aid to the operator. Under no condition should it be relied upon to replace use of capacity charts and operating instructions. Sole reliance upon LOAD MOMENT INDICATOR (AML-M) aids in place of good operating practice can cause an accident. The operator must exercise caution to assure safety.

ASTHA STERLING CRANE

DIMENSIONS

(20.5 X 25 Tires)

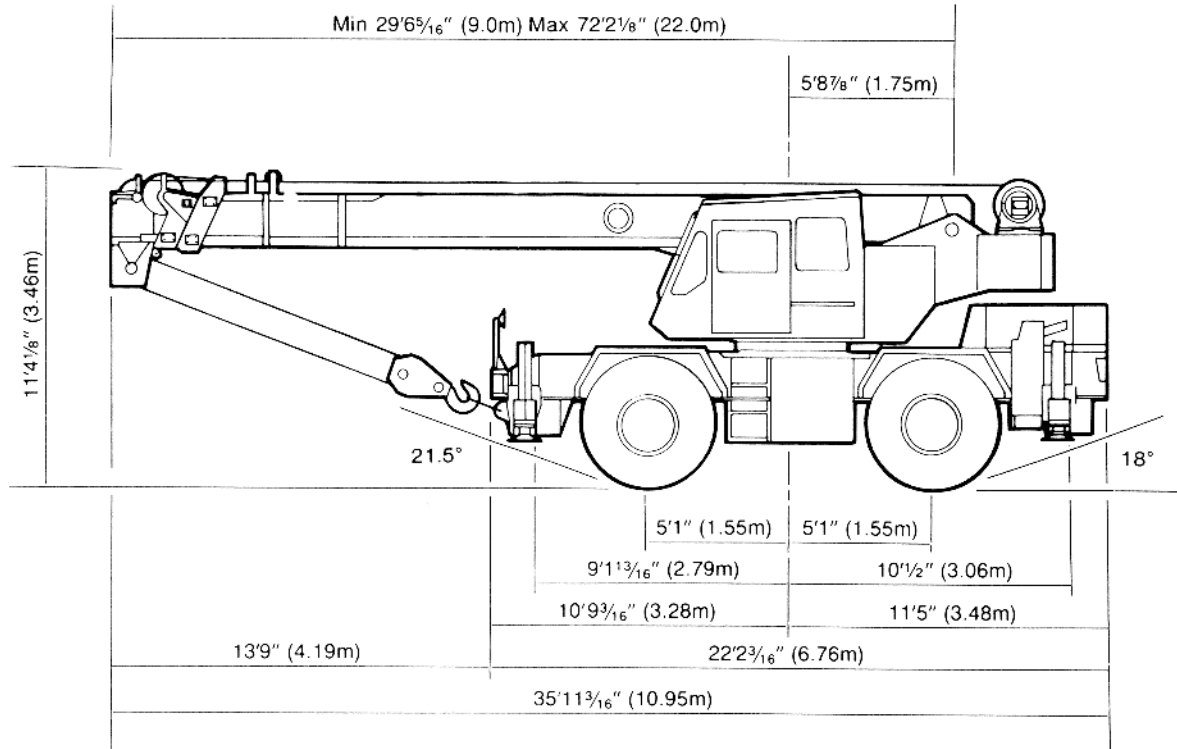

GENERAL DIMENSIONS (20.5 X 25 Tires)

| | Feet | Meters |
|--------------------------|-------------|--------|
| Tail swing counterweight | 9' 8 1/8" | 2.95 |
| Turning Radius: | | |
| 4 wheel steer | 20' 11 3/4" | 6.4 |
| 2 wheel steer | 35' 9 1/8" | 10.9 |

